



AMP NETCONNECT

Cabinet and Rack System



Cabinet and Rack System

AMP NETCONNECT 19" NETWORK AND SERVER RACK SYSTEM.

Product development was driven by the need to solve troubles of cabinet rack usage as well as to provide a cabinet that will efficient networking, reliability, and security to meet the needs of any discerning users of cabinet rack.

CABINET FRAME

Made from high quality metal white sheet durable and rustproof material, black paint color, Adjustable depth access allows easy cable management from front with guide slot for easy install and setup, removable both-side doors enables easy equipment installation and stable joint with baying kit. Four pole are a square hole rack is very easy to use and boltless able to move front and back side to adjust deep to all server type required , include an indicator Unit High number print on the front and rear of the rack to help identify a machine needing attention

DOOR OPTIONS

Acrylic Door suitable for open area or without air conditioned system as acrylic door will protects your equipments from dust.

Flat Perforate Door suitable for Data Center or in air conditioned system as perforate door for ventilation and guaranty cool air to flow though inside easier and cool down all system inside cabinet easy setup and compatible with all panel enclosure.

Curve Perforate Door is specifically designed for Data Center or in air conditioned environments system as perforate door for ventilation and guaranty cool air to flow though inside easier and cool down all system inside cabinet conditioned that will improves space and airflow active cooling can be focused on the areas where high heat dissipation is require and not be wasted on cooling traditional passive cable easy setup and compatible with all panel enclosure. Curve Perforate is design for support angle and Hi-D angle patch panel and enclosure to prevent patching cable in front of rack to bend by the front door

ACCESSORY

Accommodate general accessories as well as its own custom set of options. Options include Fixed Shelf, Heavy Duty Shelf, Slide Shelf, Ventilation Shelf, Ventilation Fan Set, and Power Distribution Unit.

PRODUCT STNADARD AND QUALITY

AMP NETCONNECT RACK meets quality standards which ANSI/EIA-310D-1992 (Rev.EIA-310C), IEC 60297-1 IEC 60297-2, BS 5954: Part 2, DIN 41494

MANUFACTORY STANDARD

ISO 9001:2000
ISO 14001



Cabinet and Rack System

Cabinet and Rack System

Acrylic Door, 600 and 800 Series



Front Side



Back Side

Features

- Modular knock-down, full assembled and easy to assembly on site.
- Material :cold rolled steel, white sheet comply to RoHS standard, frame made of 2mm steel durable and rustproof, able to adjust depth for all 4 poles.
- Front door, Acrylic 5mm clear visible inside protect from dust with handle lock for security able to setup to open from left or right side.
- Back door, steel plate double side, 2 small half door for space saving with turn lock key for security.
- Side cover, metal plate able to move with latch lock and key
- Stands, four stand metal, easy to adjust.
- Casters, four Nylon caster able to turn 360 degree easy to move.
- Cable routing from top and bottom, top roof hole able to install ventilation fan set 2 – 6 fans and able to close with blank plate if not use.
- Static loading 1000 Kg.
- Ground system, all part are bonding together with grounding cable kits.
- Include cable tray left and right for 800 Series
- Accessory provides M6 bolts, and cage nuts.
- Color, Black

Product Selection

Description	UH	600 Series (WXD)			800 Series (WXD)	
		600X600	600X800	600X1100	800X800	800X1100
Standard Rack 15U, ACD	15	1-1427502-1	1-1427503-1	1-1427504-1	1-1427505-1	1-1427506-1
Standard Rack 27U, ACD	27	2-1427502-1	2-1427503-1	2-1427504-1	2-1427505-1	2-1427506-1
Standard Rack 36U, ACD	36	3-1427502-1	3-1427503-1	3-1427504-1	3-1427505-1	3-1427506-1
Standard Rack 42U, ACD	42	4-1427502-1	4-1427503-1	4-1427504-1	4-1427505-1	4-1427506-1

Cabinet and Rack System

Acrylic Door, 600 Series

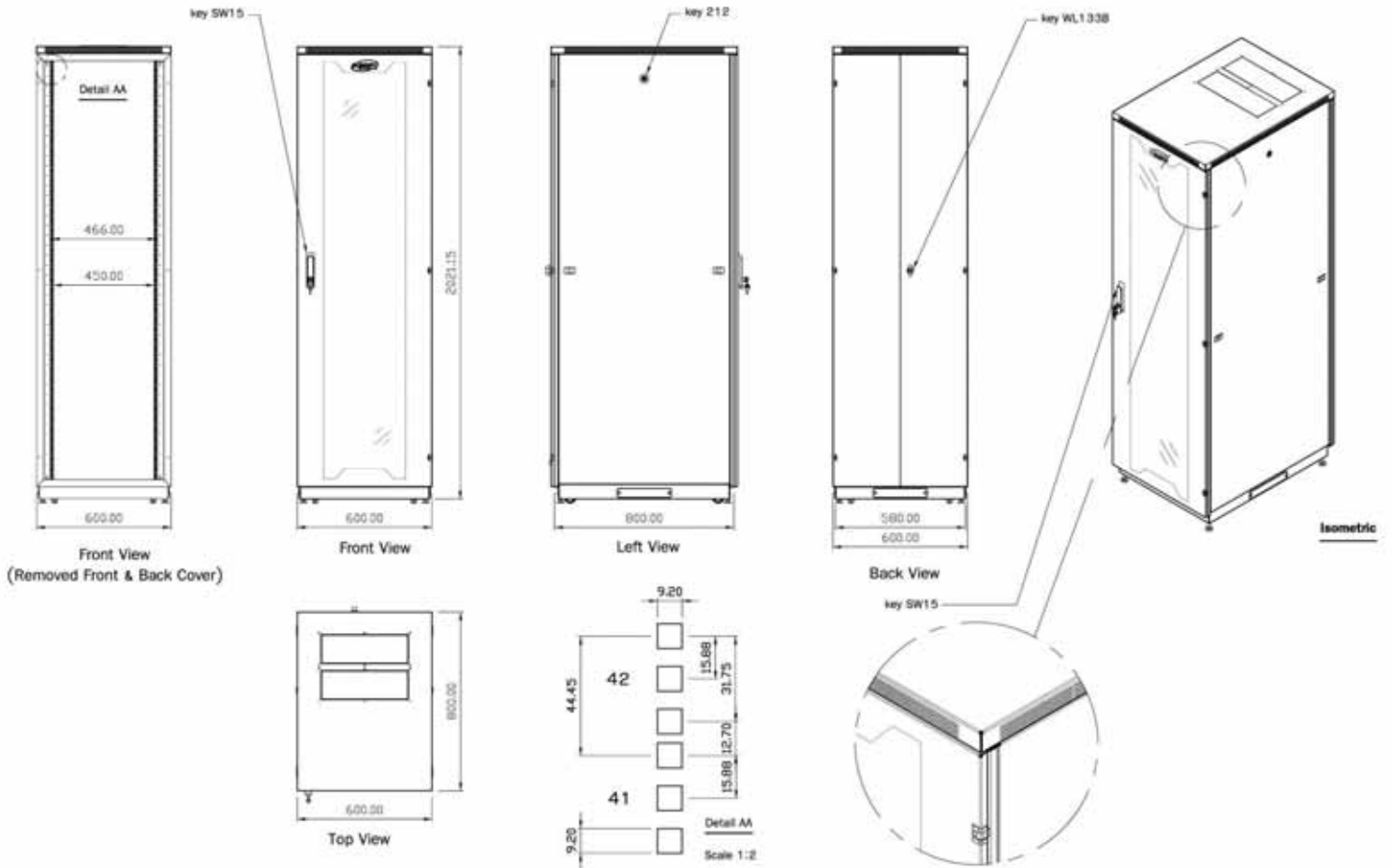

Product Specification

UH	600 Series (WXD) mm								
	600X600			600X800			600X1100		
	W	D	H	W	D	H	W	D	H
15	600	600	821	600	800	821	600	1100	821
27	600	600	1354	600	800	1354	600	1100	1354
36	600	600	1754	600	800	1754	600	1100	1754
42	600	600	2021	600	800	2021	600	1100	2021

Cabinet and Rack System

Cabinet and Rack System

Acrylic Door, 800 Series

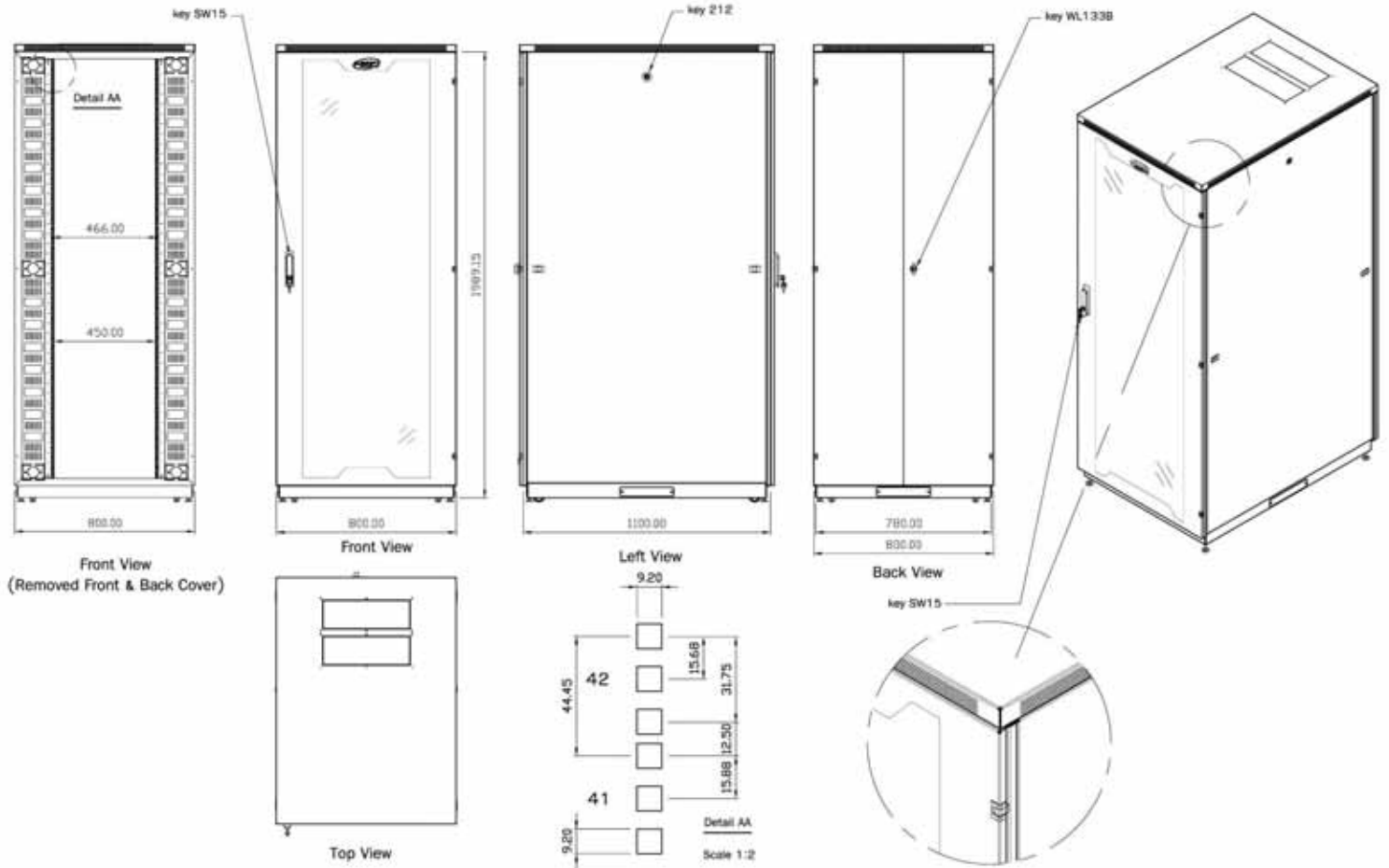

Product Specification

UH	800 Series (WxD) mm					
	800X800			800X1100		
	W	D	H	W	D	H
15	800	800	821	800	1100	821
27	800	800	1354	800	1100	1354
36	800	800	1754	800	1100	1754
42	800	800	2021	800	1100	2021

Cabinet and Rack System

Flat Perforate Door, 600 and 800 Series



Front Side



Back Side

Features

- Modular knock-down, full assembled and easy to assembly on site.
- Material :cold rolled steel, white sheet comply to RoHS standard, frame made of 2mm steel durable and rustproof, able to adjust depth for all 4 poles.
- Front door, Flat Perforate steel with handle lock for security able to setup to open from left or right side.
- Back door, Flat Perforate steel double side, 2 small half door for space saving with turn lock key for security.
- Side cover, metal plate able to move with latch lock and key
- Stands, four stand metal, easy to adjust.
- Casters, four Nylon caster able to turn 360 degree easy to move.
- Cable routing from top and bottom, top roof hole able to install ventilation fan set 2 – 6 fans and able to close with blank plate if not use.
- Static loading 1000 Kg.
- Ground system, all part are bonding together with grounding cable kits.
- Include cable tray left and right for 800 Series
- Accessory provides M6 bolts, and cage nuts.
- Color, Black

Product Selection

Description	UH	600 Series (WXD)			800 Series (WXD)	
		600X600	600X800	600X1100	800X800	800X1100
Standard Rack 15U, FPD	15	1-1427502-2	1-1427503-2	1-1427504-2	1-1427505-2	1-1427506-2
Standard Rack 27U, FPD	27	2-1427502-2	2-1427503-2	2-1427504-2	2-1427505-2	2-1427506-2
Standard Rack 36U, FPD	36	3-1427502-2	3-1427503-2	3-1427504-2	3-1427505-2	3-1427506-2
Standard Rack 42U, FPD	42	4-1427502-2	4-1427503-2	4-1427504-2	4-1427505-2	4-1427506-2

Cabinet and Rack System

Flat Perforate Door, 600 Series

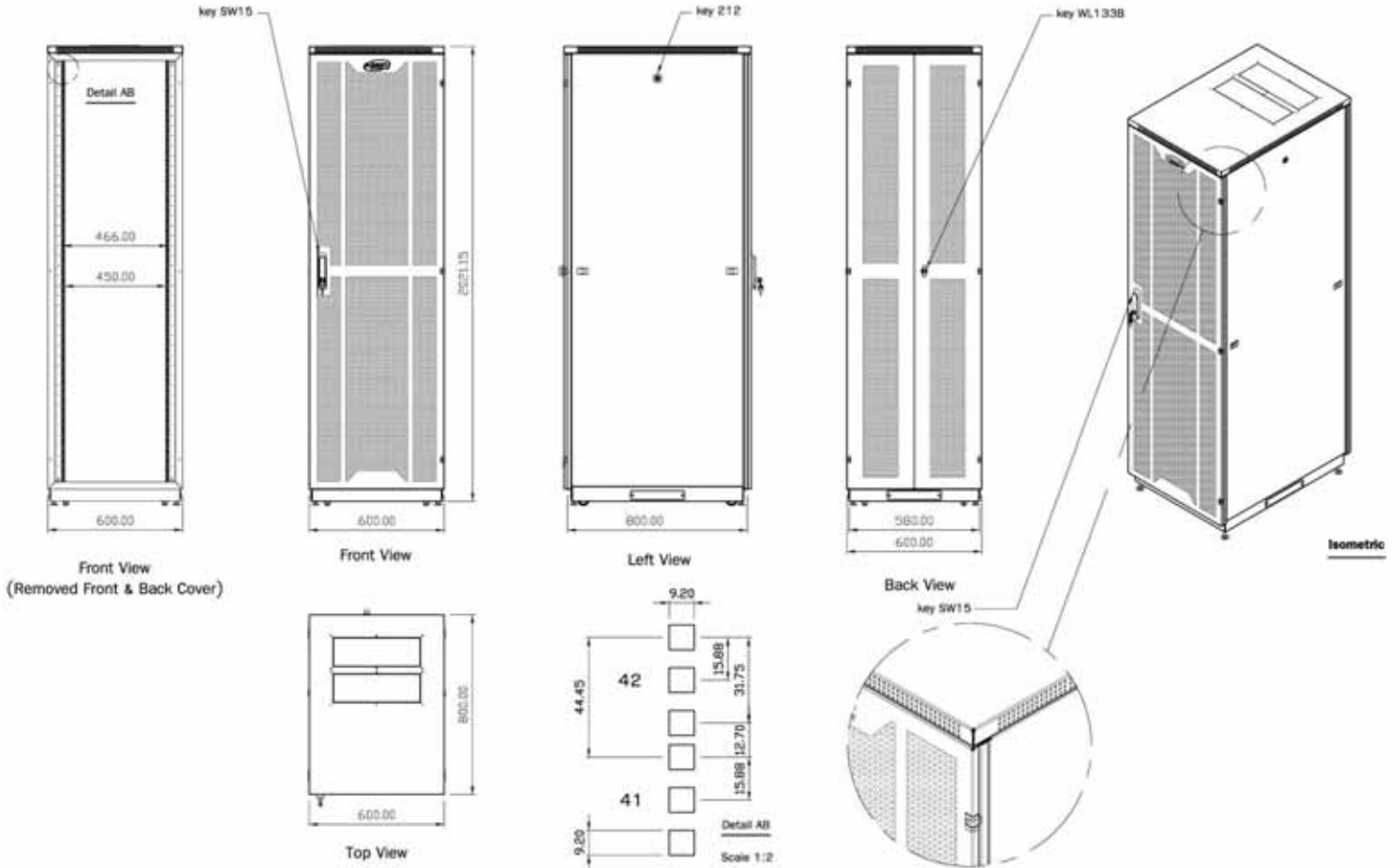

Product Specification

UH	600 Series (WXD) mm								
	600X600			600X800			600X1100		
	W	D	H	W	D	H	W	D	H
15	600	600	821	600	800	821	600	1100	821
27	600	600	1354	600	800	1354	600	1100	1354
36	600	600	1754	600	800	1754	600	1100	1754
42	600	600	2021	600	800	2021	600	1100	2021

Cabinet and Rack System

Flat Perforate Door, 800 Series

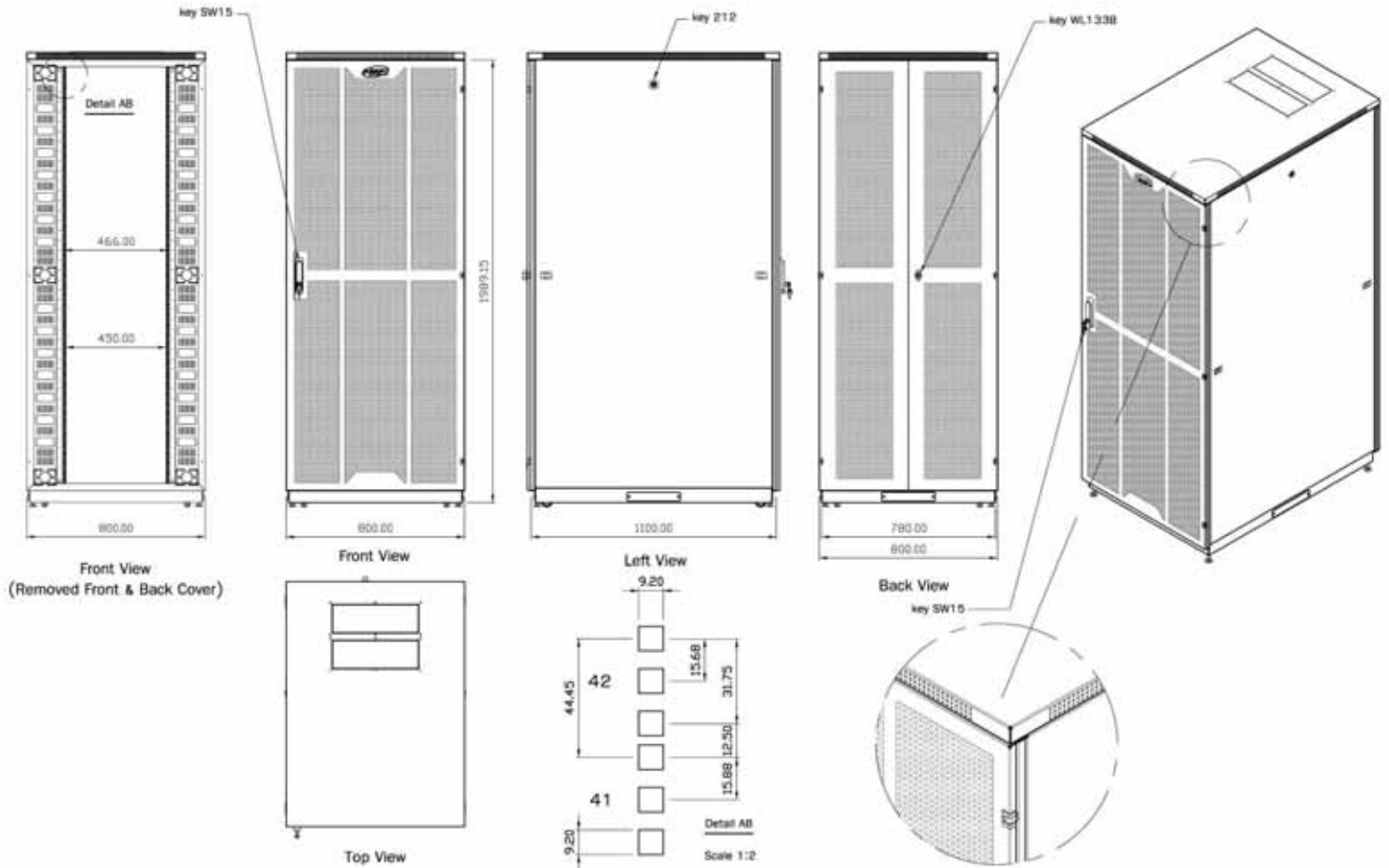

Product Specification

UH	800 Series (WXD) mm					
	800X800			800X1100		
	W	D	H	W	D	H
15	800	800	821	800	1100	821
27	800	800	1354	800	1100	1354
36	800	800	1754	800	1100	1754
42	800	800	2021	800	1100	2021

Cabinet and Rack System

Curve Perforate Door, 600 and 800 Series



Front Side



Back Side

Features

- Modular knock-down, full assembled and easy to assembly on site.
- Material :cold rolled steel, white sheet comply to RoHS standard, frame made of 2mm steel durable and rustproof, able to adjust depth for all 4 poles.
- Front door, Curve Perforate steel with handle lock for security able to setup to open from left or right side.
- Back door, Flat Perforate steel double side, 2 small half door for space saving with turn lock key for security.
- Side cover, metal plate able to move with latch lock and key
- Stands, four stand metal, easy to adjust.
- Casters, four Nylon caster able to turn 360 degree easy to move.
- Cable routing from top and bottom, top roof hole able to install ventilation fan set 2 – 6 fans and able to close with blank plate if not use.
- Static loading 1000 Kg.
- Ground system, all part are bonding together with grounding cable kits.
- Include cable tray left and right for 800 Series
- Accessory provides M6 bolts, and cage nuts.
- Color, Black

Product Selection

Description	UH	600 Series (WXD)			800 Series (WXD)	
		600X600	600X800	600X1100	800X800	800X1100
Standard Rack 15U, CPD	15	1-1427502-3	1-1427503-3	1-1427504-3	1-1427505-3	1-1427506-3
Standard Rack 27U, CPD	27	2-1427502-3	2-1427503-3	2-1427504-3	2-1427505-3	2-1427506-3
Standard Rack 36U, CPD	36	3-1427502-3	3-1427503-3	3-1427504-3	3-1427505-3	3-1427506-3
Standard Rack 42U, CPD	42	4-1427502-3	4-1427503-3	4-1427504-3	4-1427505-3	4-1427506-3

Cabinet and Rack System

Curve Perforate Door, 600 Series

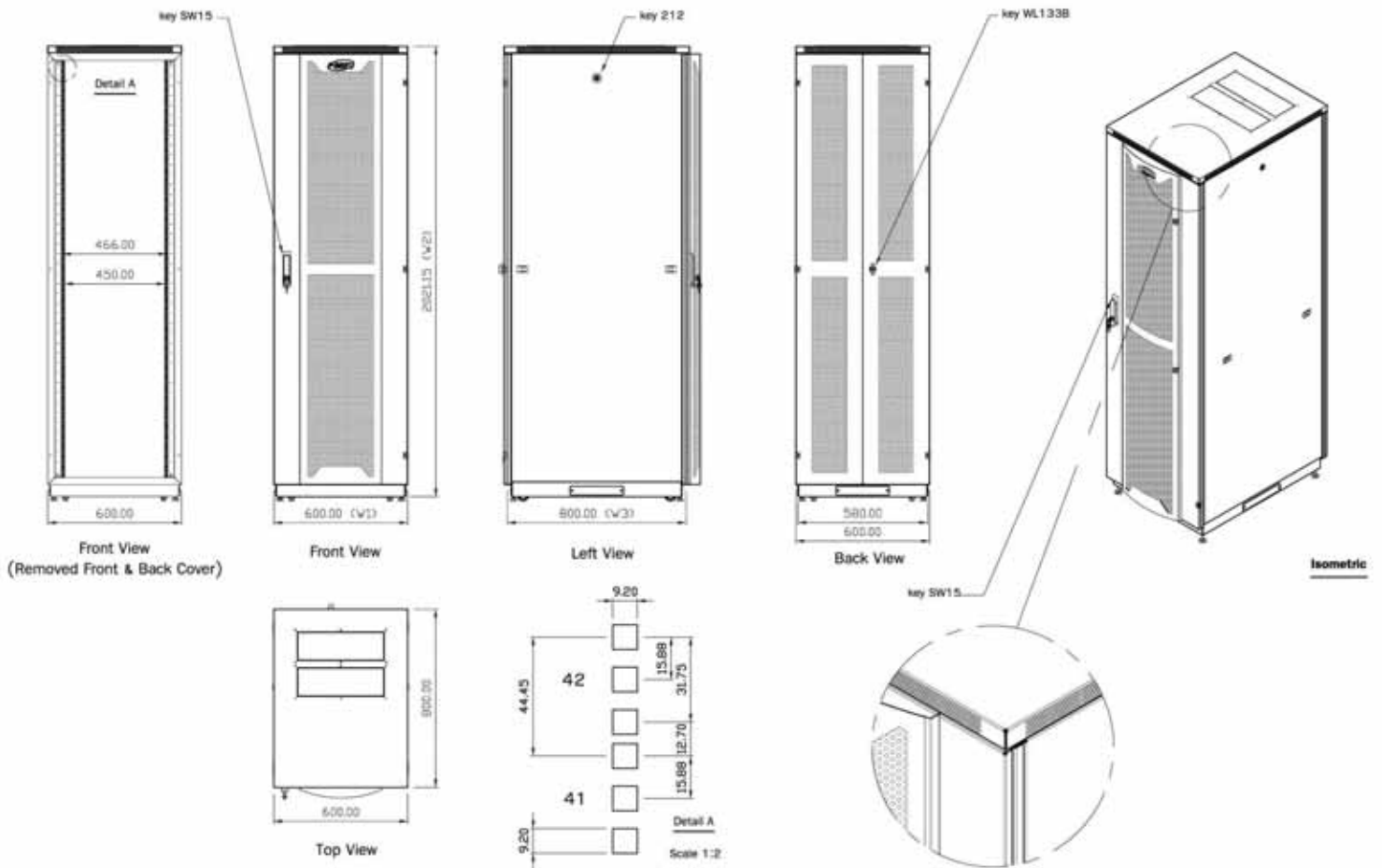

Product Specification

UH	600 Series (WXD) mm								
	600X600			600X800			600X1100		
	W	D	H	W	D	H	W	D	H
15	600	600	821	600	800	821	600	1100	821
27	600	600	1354	600	800	1354	600	1100	1354
36	600	600	1754	600	800	1754	600	1100	1754
42	600	600	2021	600	800	2021	600	1100	2021

Cabinet and Rack System

Curve Perforate Door, 800 Series

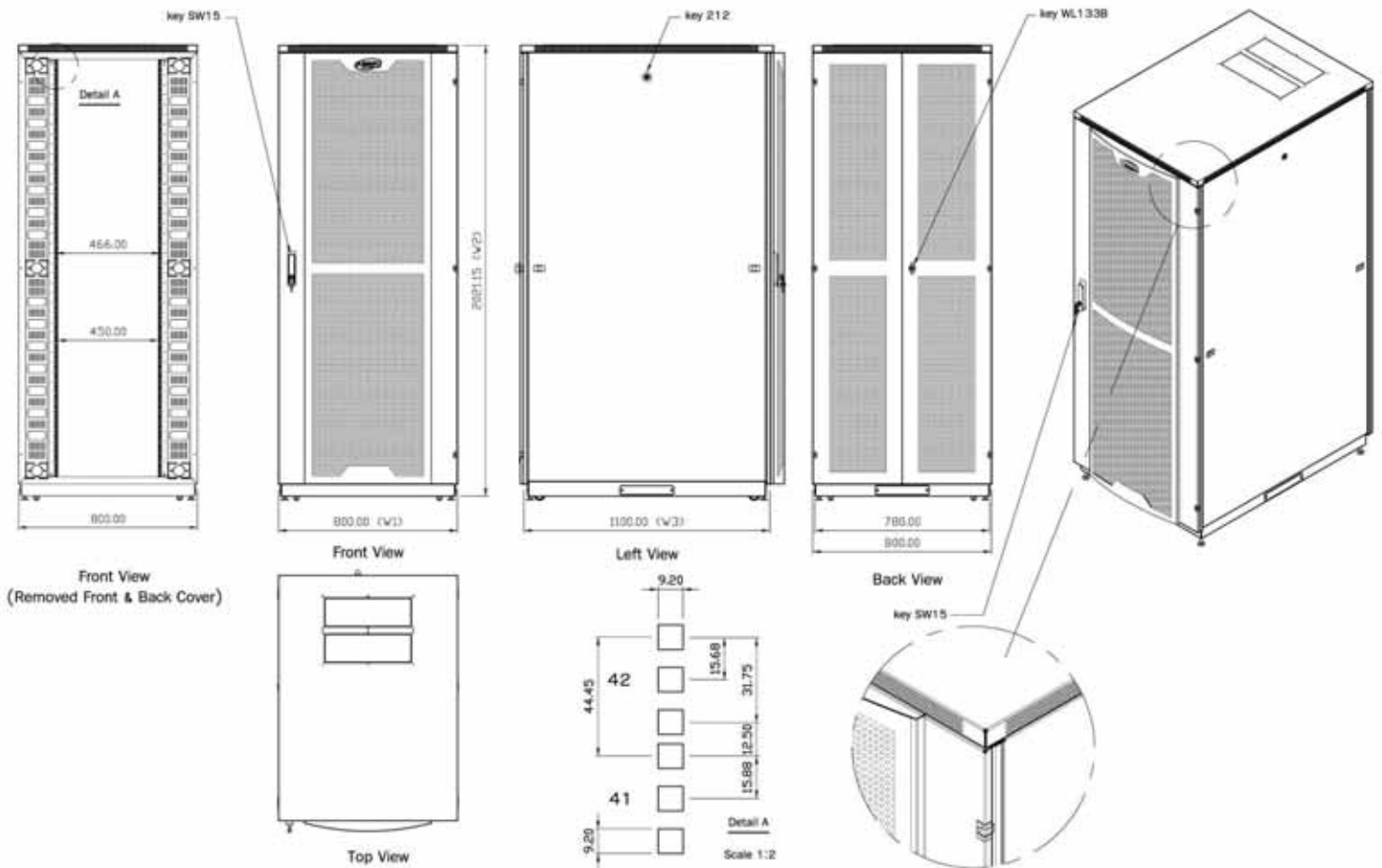

Product Specification

UH	800 Series (WxD) mm					
	800X800			800X1100		
	W	D	H	W	D	H
15	800	800	821	800	1100	821
27	800	800	1354	800	1100	1354
36	800	800	1754	800	1100	1754
42	800	800	2021	800	1100	2021

Cabinet and Rack System

Wall Rack Acrylic Door, 500 and 650 Series



Features

- Modular knock-down, full assembled and easy to assembly on site.
- 3 section designed back for wall mounting, middle for equipment mounting and able to swing open for easy installation and maintenance with master key lock able to use for both front and side key lock, third section acrylic door.
- Material: cold rolled steel, white sheet comply to RoHS standard, frame made of 2mm steel durable and rustproof, able to adjust depth for all 2 poles.
- Front door, Metal Frame with Acrylic 5mm clear visible inside protect from dust with collapse key lock for security able to setup to open from left or right side.
- Back Side able to install on the wall by 4 screw with 2 layer steel holder for heavy duty support
- Side cover, metal plate with perforate at bottom for better air flow.
- Cable routing from top bottom, left and right side, top roof hole able to install ventilation fan set 2 – 3 fans and able to close with blank plate if not use.
- Ground system, all part are bonding together with grounding cable kits.
- Accessory provides M6 bolts, and cage nuts and Screw for Wall Mounting Kit.
- Color, Black

Product Selection

Description	UH	500 Series (WXD)	650 Series (WXD)
		600X500	600X650
Wall Rack 6U, ACD	6	1427517-1	1427520-1
Wall Rack 9U, ACD	9	1427518-1	1427521-1
Wall Rack 12U, ACD	12	1427519-1	1427522-1

Cabinet and Rack System

Wall Rack Curve Perforate Door, 500 and 650 Series



Features

- Modular knock-down, full assembled and easy to assembly on site.
- 3 section designed back for wall mounting, middle for equipment mounting and able to swing open for easy installation and maintenance with master key lock able to use for both front and side key lock, third section curve perforate door.
- Material: cold rolled steel, white sheet comply to RoHS standard, frame made of 2mm steel durable and rustproof, able to adjust depth for all 2 poles.
- Front door, Metal Curve Perforate with collapse key lock for security able to setup to open from left or right side.
- Back Side able to install on the wall by 4 screw with 2 layer steel holder for heavy duty support
- Side cover, metal plate with perforate at bottom for better air flow.
- Cable routing from top bottom, left and right side, top roof hole able to install ventilation fan set 2 – 3 fans and able to close with blank plate if not use.
- Ground system, all part are bonding together with grounding cable kits.
- Accessory provides M6 bolts, and cage nuts and Screw for Wall Mounting Kit.
- Color, Black

Product Selection

Description	UH	500 Series (WXD)	650 Series (WXD)
		600X500	600X650
Wall Rack 6U, CPD	6	1427517-2	1427520-2
Wall Rack 9U, CPD	9	1427518-2	1427521-2
Wall Rack 12U, CPD	12	1427519-2	1427522-2

Wall Rack 500 and 650 Series

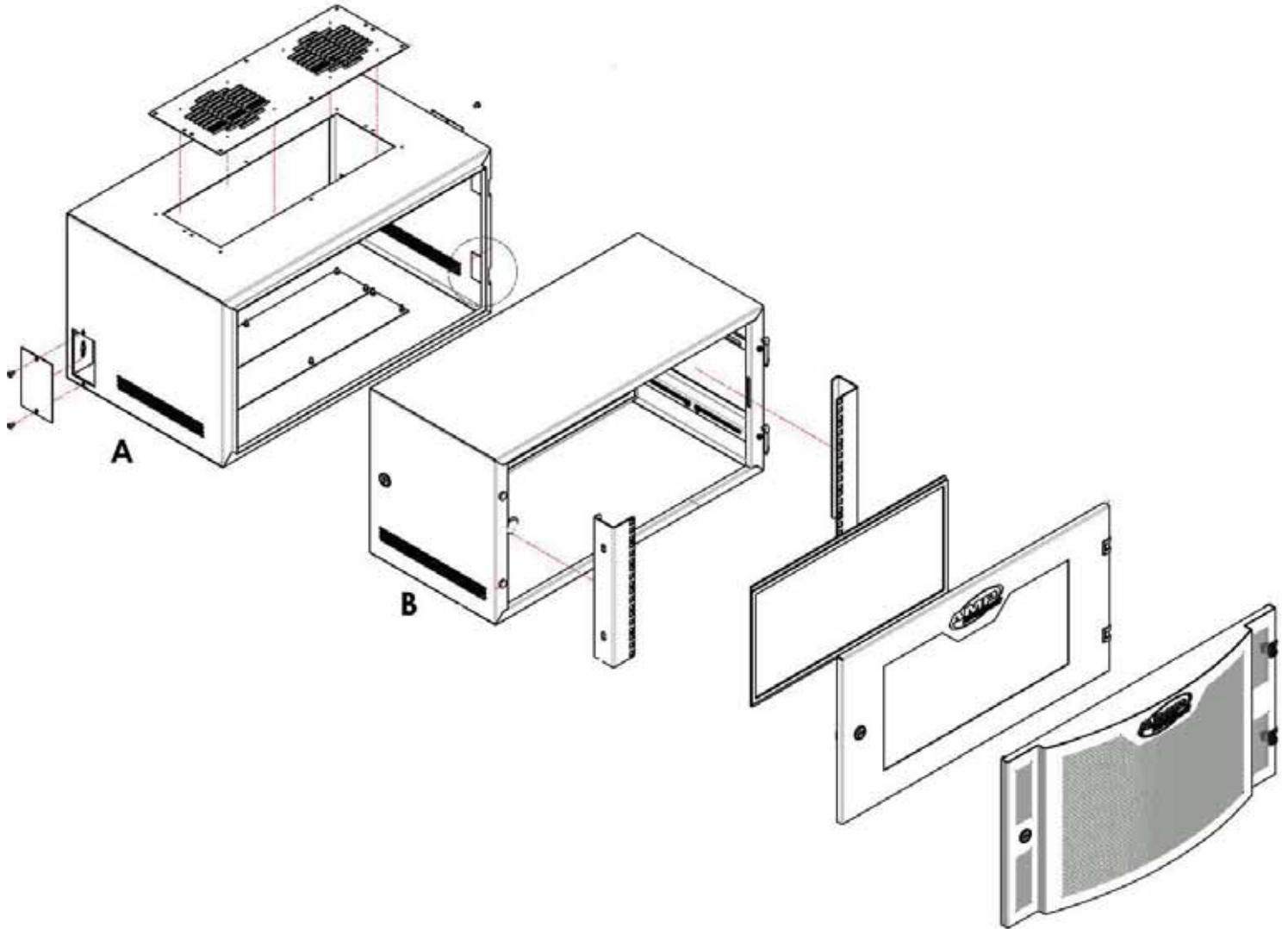

Product Specification

UH	Wall Rack (WXDXH) mm					
	500 Series			650 Series		
	W	D	H	W	D	H
6	600	500	320	600	650	320
9	600	500	453	600	650	453
12	600	500	586	600	650	586

Rack Accessory

AC POWER DISTRIBUTION UNIT



- Power Distribution Unit (PDU) 220V AC, 6 or 12 Outlets with Ground Cord (L,N,G)
- Circuit breaker protection and indicator status
- 3 m. power cord plug
- Other size, please call for information

Description	Part Number
AC PDU,6 Outlet, 15A, Standard	1427507-1
AC PDU,12 Outlet, 15A, Standard	1427507-2
AC PDU,6 Outlet , 30A, Power Plug	1-1427507-1
AC PDU,12 Outlet, 30A, Power Plug	1-1427507-2

AC POWER DISTRIBUTION UNIT

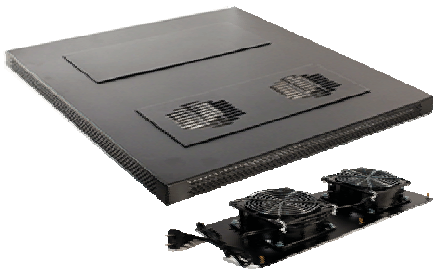

- Trays available with either two or tree 4 inch fans are typically located in the top of the cabinet for versatility
- 1 m. power cord plug
- Rated at 220-240 V AC, 50-60 Hz

Description	Part Number
Ventilating Fan Set 2X4" Dia	1427508-1
Ventilating Fan Set 3X4" Dia	1427508-2

VENTED SHELVE 400 MM DEEP

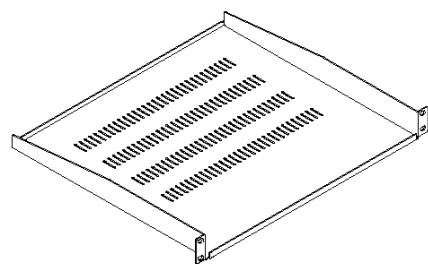

- Supports equipment up to 40 cm. deep with 1U height
- Compatible with 19" Racks
- Up to 20 kg. load capacity, able to take the weight of equipments installation such as Modem, Power Adapter
- Made from Black Solid Steel

Description	Part Number
Vented Shelve 400 mm Depth	1427509-1

Cabinet and Rack System

FIXED SHELF&HEAVY DUTY SHELF



- These Fixed and Heavy Duty Shelves are ideal for heavy load equipments
- Compatible with 19" Racks, 1U height, mounting hardware included
- Made from vented black metal
- 80 Kg capacity for Fixed Shelf series
- 300 Kg capacity for Heavy Duty Shelf series
- Compatible with 600, 800 and 1100 deep cabinets

Description	Part Number
Fixed Shelf, for 600 Series, (450 mm depth)	1427510-1
Heavy Duty Shelf, for 600 Series, (450 mm depth)	1427510-2
Fixed Shelf, for 800 Series, (600 mm depth)	1427510-3
Heavy Duty Shelf, for 800 Series, (600 mm depth)	1427510-4
Fixed Shelf, for 1100 Series, (800 mm depth)	1427510-5
Heavy Duty Shelf, for 1100 Series, (800 mm depth)	1427510-6

SLIDE SHELF

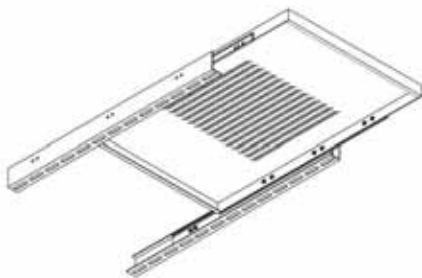

- These Slide Shelves are ideal for equipments and all part need to often move in and out
- Compatible with 19" Racks, 1U height, mounting hardware included
- Made from vented black metal
- 40 Kg capacity load
- Compatible with 600, 800 and 1100 deep cabinets

Description	Part Number
Slide Shelf, for 600 Series, (450 mm depth)	272363-1
Slide Shelf, for 800 Series, (600 mm depth)	272363-2
Slide Shelf, for 1100 Series, (800 mm depth)	272363-3

Cabinet and Rack System



Hi-D ANGLE CABLE MANAGEMENT

- Rack density increased by up to 50%
- Compatible with 19" Standard Rack 80 cm width
- Professional cable routing, finger slot for fix the cable
- Reliable and safe maintenance
- Lower operational cost fast MACs
- Bend radius control for copper and fiber required by ISO/IEC 11801 and TIA/EIA 568B Standard

Description	Part Number
Angle Cable Management Kit, Left & Right, 2UH	1427515-1
Angle Cable Management Kit, Left & Right, 6UH	1427516-1



VELCRO CABLE TIES

For 8-inch and 12-inch ties, an order quantity of one equals one roll of ten ties, easier and flexible to managed cable in cabinet rack and cable tray

Description	Part Number
1"X8" VELCRO CABLE TIES, BLACK (10 piece per roll)	1375253-2
1"X12" VELCRO CABLE TIES, BLACK (10 piece per roll)	1375254-2

For more information;

Tyco Electronics (Thailand) Limited

Website: <http://www.ampnetconnect.com/thailand>

Email: ampth.connect@tycoelectronics.com

Tel. 02-834-6233, 02-834-6224, **Call Center: 085-224-5000**

Catalog No 273007, Rev C, April 2010